

AVERY DENNISON MARKETING SPECIFICATION

HISTORY

THE SUBJECT MATTER DISCLOSED HEREIN EMBODIES PROPRIETARY INFORMATION WHICH IS THE CONFIDENTIAL PROPERTY OF THE AVERY DENNISON CO. NONE OF WHICH SHALL BE COPIED, REPRODUCED, DISCLOSED TO OTHERS, PUBLISHED OR USED IN WHOLE OR IN PART, FOR ANY PURPOSE OTHER THAN THAT FOR WHICH IT IS BEING MADE AVAILABLE WITHOUT THE EXPRESS ADVANCE WRITTEN PERMISSION OF A DULY AUTHORIZED AGENT OF THE COMPANY. THIS DOCUMENT IS THE PROPERTY OF THE AVERY DENNISON CO. AND IS TO BE RETURNED TO THE COMPANY ON DEMAND.

REV.	DATE	DESCRIPTION
A	6-26-13	RELEASED
B	11-20-15	UPDATED DIM 1 AND DIM 4 TO ACTUAL PART NOMINAL DIM

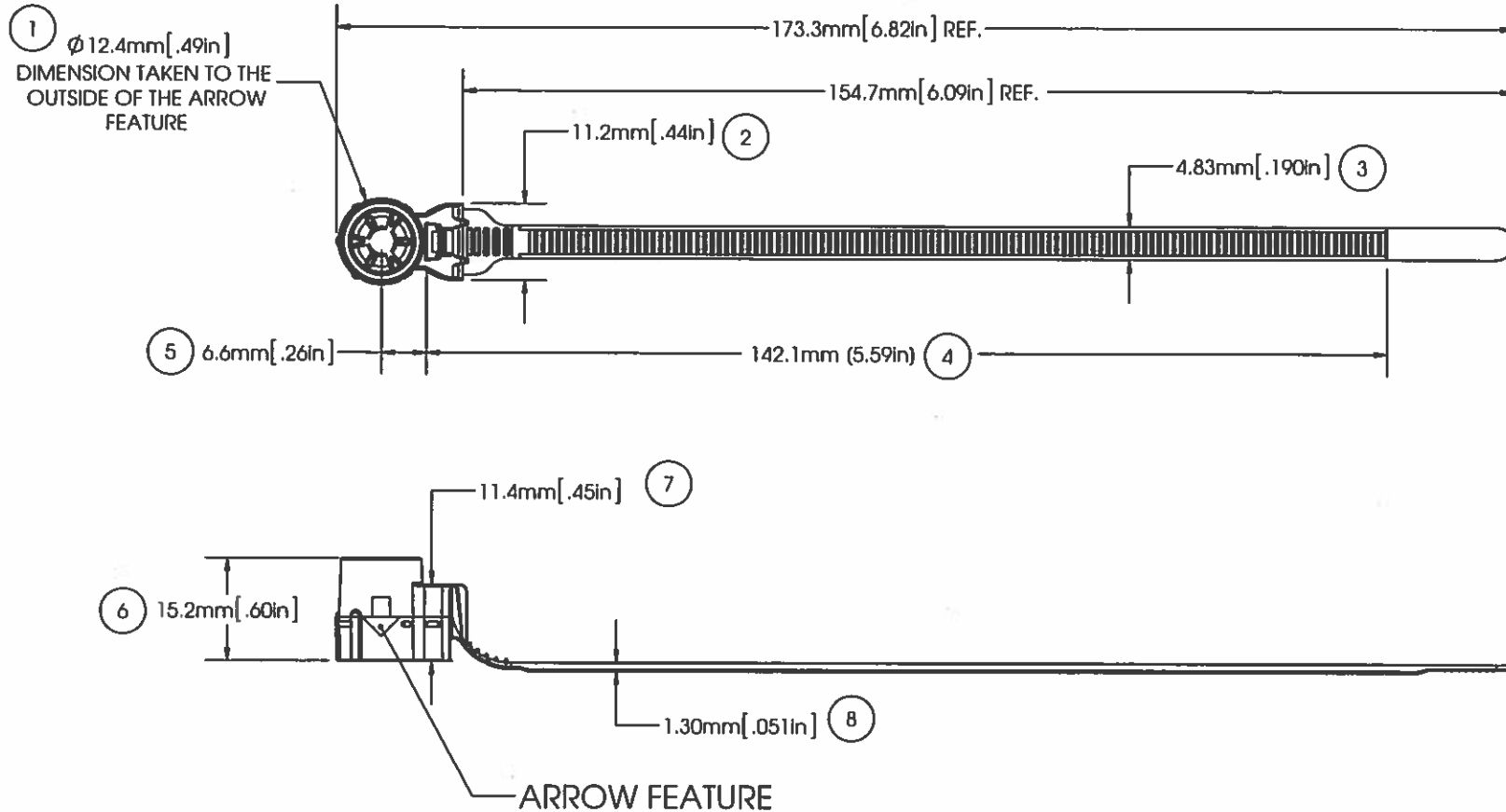

MOUNTING:	M5 AND T5 STUD
TENSILE STRENGTH:	50 LBF / 222N MIN.
WEIGHT:	2.23 GRAMS
TEMPERATURE RANGE:	-40°F (-40°C) TO 239°F (115°C) CONTINUOUS AND 257°F (125°C) AT MAXIMUM EXPOSURE
BUNDLE DIAMETER:	Ø 1.6MM TO Ø 38.1MM
TOOL:	12001- HAND INSTALLATION TOOL 12500- PNUM. INSTALLATION TOOL
TOOL TENSION SETTING:	6 - 8
PACKAGING:	1000/BAG, 5 BAGS/MASTER

APPROVALS: ENG. APPR. *[Signature]* 11/20/15
Q.A. APPR. *[Signature]* 11/20/15

SPECIFIED TOLERANCES ARE:

.XX ± .03 INCHES .X ± .7 MM
.XXX ± .01 INCHES .XX ± .25 MM
ANGULAR: ± 2°

MATERIAL: NYLON 6/6,
IMPACT MODIFIED, HEAT STABILIZED

COLOR: GREY

AVERY DENNISON
FASTENER DIVISION
FITCHBURG, MA 01420 U.S.A.
TEL: 1-800-225-5913
FAX: 978-353-8157

DESCRIPTION: T5, M5 COMPACT
WELD STUD TIE

STOCK NO. 20145-0

REV. B